

Installation dimensions

KWB Powerfire 130/150kW

A minimum unobstructed door width of 1.20 m is necessary to be able to move the system into the room in a pre-assembled state. Door height should be 2 m. For a prompt and trouble-free installation, it is necessary to inform KWB of the unobstructed door widths in the planning stage. Due to the weight of the ash container a lifting device is recommended for stair access to the boiler room.

View from the right

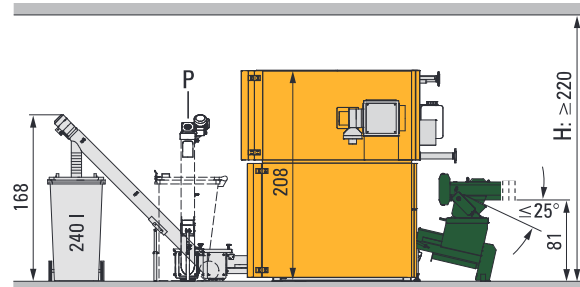

External ash container on the left (A3)

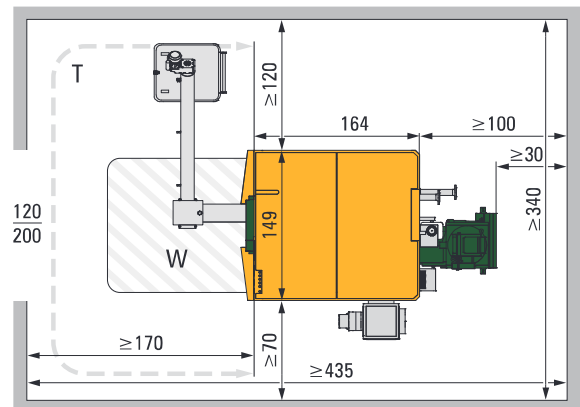

External ash container in front (A1)

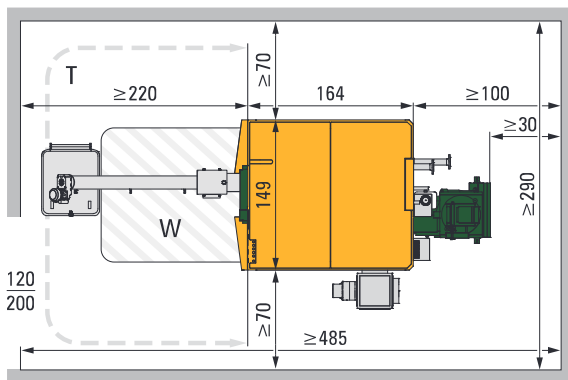

External ash container right (A4)

(with swing range of the fuel extractor and wall duct)

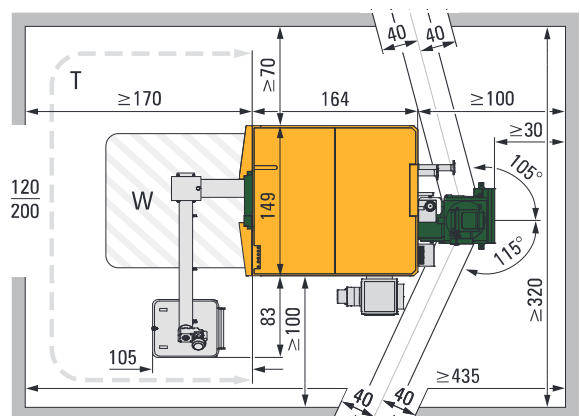

Internal ash container (A2)

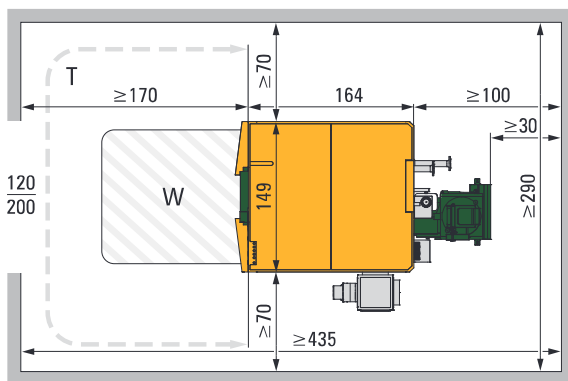

Minimum room dimensions

Minimum room dimensions of the built-in ash container variants (cm)					
Version:	Ash-container position				
	Left	Right	Front	Internal	Any
Room width (B)	290	290	340	320	370
Room length (L)	485	435	435	435	485
Room height (H)	220	220	220	220	220

Legend

H	Room height: For room heights below 280 cm, the customer must provide suitable lifting tools (electrical forklift, wheel front loader, etc.).
P	Alternative position
T	Door area: valid for all models. The door must be in the drawn-in area – deviations require consultation with KWB! If the door is not directly in front of the system, the space requirement in front of the system increases to at least ≥220 cm.
W	Maintenance area

REI90 according to ÖNORM EN 13501, EI₃₀-C according to ÖNORM EN 13501, E30 according to ÖNORM EN 13501

All distances stated are minimum dimensions and apply only to the installation variants shown! With regards to space requirements also pay attention to smoke pipe routing and chimney position – the space requirement for reducers and elbows can influence the minimum distances! It must be possible to detach the entire casing at any time.

Connecting dimensions

KWB Powerfire 130/150kW

Drawing

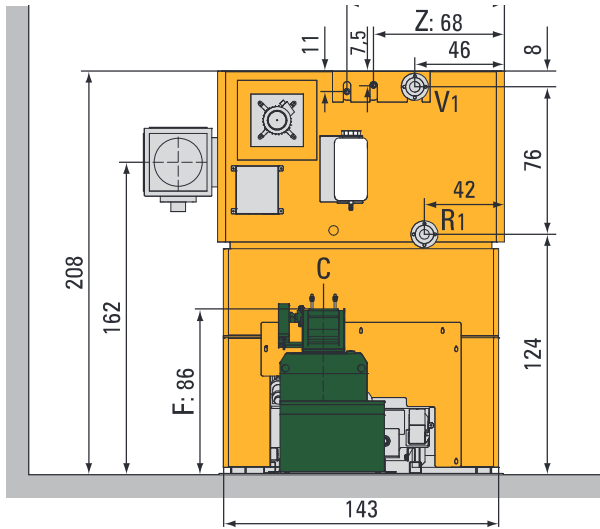

Side view with fire shutter

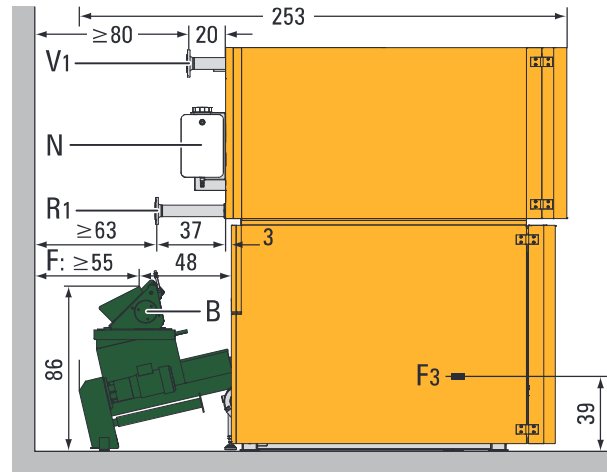

Plan view

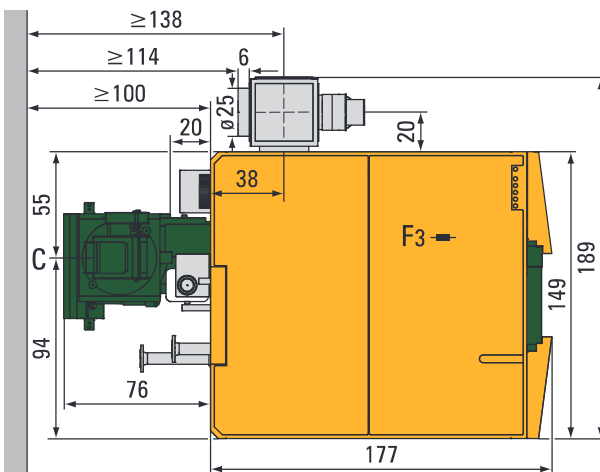

Side view with cellular wheel sluice

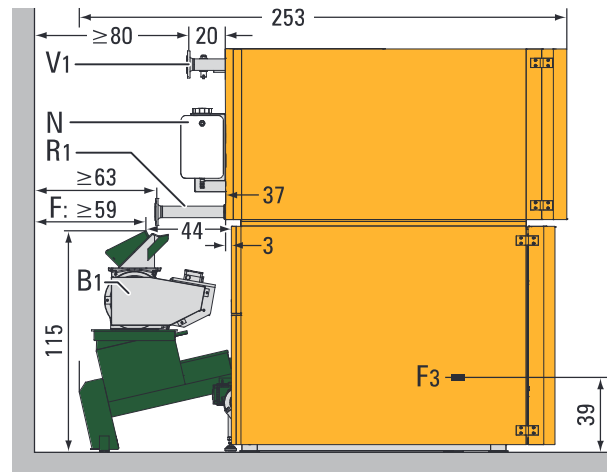

Legend

A	Outflow for thermal safety valve ¾" (internal thread)
B	Fire shutter
BI	Cellular wheel sluice (alternative to the fire shutter)
C	Conveyor system axle
EF	E-Filter
F	Conveyor system connection

F3	Boiler filling and emptying point ¾" (internal thread) - burner housing area (at the front under the combustion chamber door)
N	Emergency fire-extinguishing equipment
RI	Return flow DN 50, PN 6
VI	Forward flow DN 50, PN 6
Z	Inflow for thermal safety valve ¾" (internal thread)

All illustrations are shown without the external ash removal system. All distances stated are minimum dimensions and apply only to the installation variants shown! With regards to space requirements also pay attention to smoke pipe routing and chimney position – the space requirement for reducers and elbows can influence the minimum distances! It must be possible to detach the entire casing at any time.

Classicfire
Combifire

Easyfire 1
Easyfire 1 Plus

Easyfire

Pelletfire^{Plus}

Multifire

Powerfire

Control
C3 & C4

Conveyor and
storage
systems

Storage and
hydraulic
systems

Installation dimensions with E-Filter

KWB Powerfire 150kW with E-Filter

Standard model with E-Filter on the right

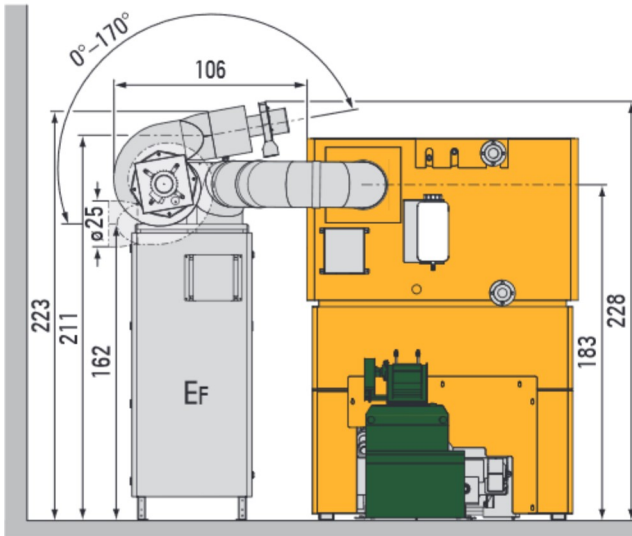

Standard model with E-Filter on the left

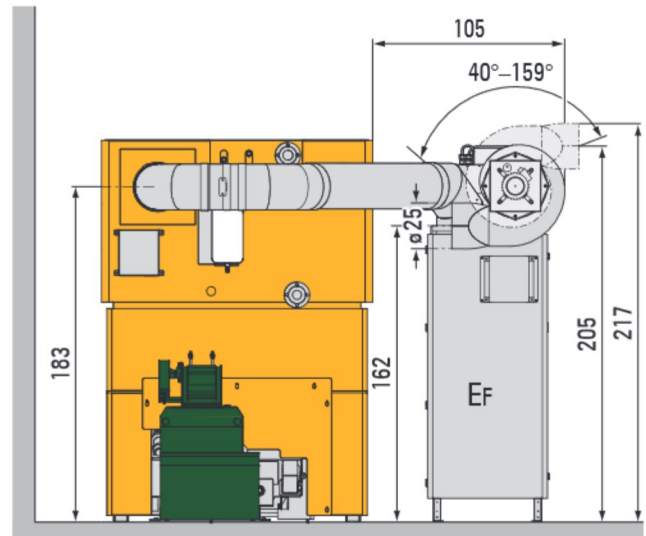

Standard model with E-Filter on the right

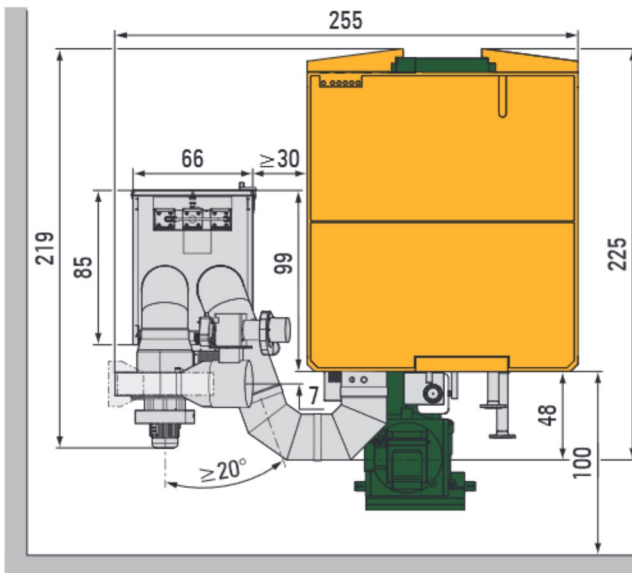

Standard model with E-Filter on the left

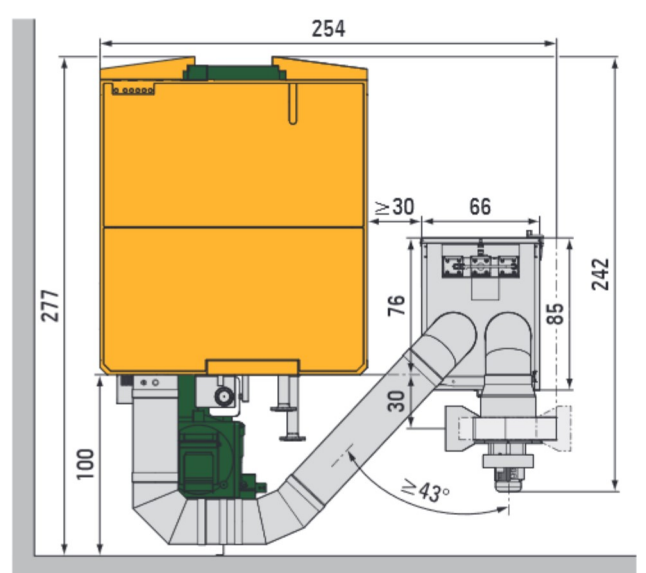

Classicfire
Combi

Easyfire 1
Easyfire 1 Plus

Easyfire

Pelletfire^{Plus}

Multifire

Powerfire

Control
C3 & C4

Conveyor and
storage
systems

Storage and
hydraulic
systems

Installation dimensions

KWB Powerfire 240/300kW

A minimum unobstructed door width of 1.40 m must be provided to be able to move the system into the room. The unobstructed door height must be 2m. The unobstructed dimensions for the system to fit in case of a ceiling duct are 1.40 x 2.2 m. For a prompt and smooth installation, it is necessary to notify KWB of the unobstructed door widths in the planning stage. Due to the weight of the ash container, we recommend a lifting device for stair access to the boiler room.

External ash container 240 l on the left (A1)

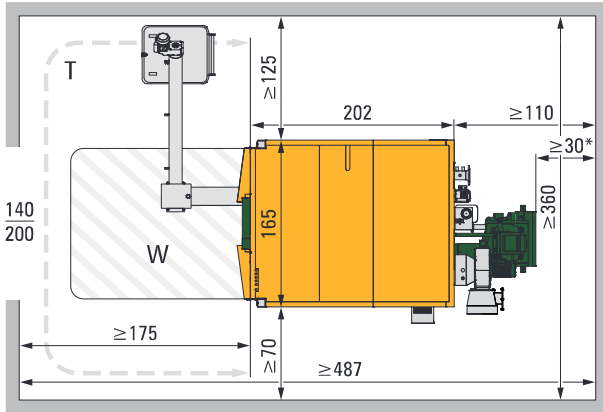

External ash container 240 l on the left (A2)

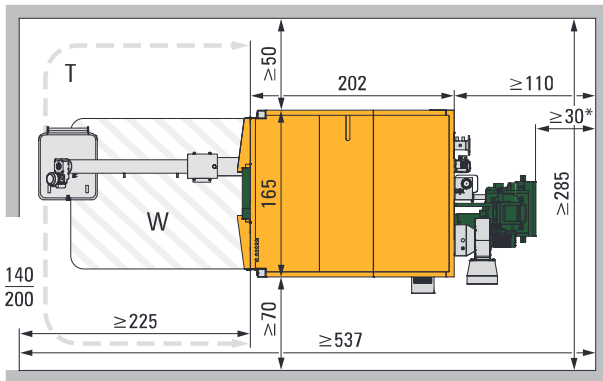

Legend

H	Room height: For room heights below 280 cm, the customer must provide suitable lifting tools (electrical forklift, wheel front loader, etc.).
P	Alternative position
T	Door area: valid for all models. The door must be in the drawn-in area – deviations require consultation with KWB! If the door is not directly in front of the system, the space requirement in front of the system increases to at least ≥225 cm.
W	Maintenance area

* If the conveyor system is installed diagonally (swing range: -105° to +115°), the planning must include an additional clearance of ≥20 cm to the rear wall! Take the gear unit position and motor position into account. RE190 according to ÖNORM EN 13501, E12 30-C according to ÖNORM EN 13501, E30 according to ÖNORM EN 13501 All distances stated are minimum dimensions and apply only to the installation variants shown! With regards to space requirements also pay attention to smoke pipe routing and chimney position – the space requirement for reducers and elbows can influence the minimum distances! It must be possible to detach the entire casing at any time.

Heat exchanger ash removal in a convenient design

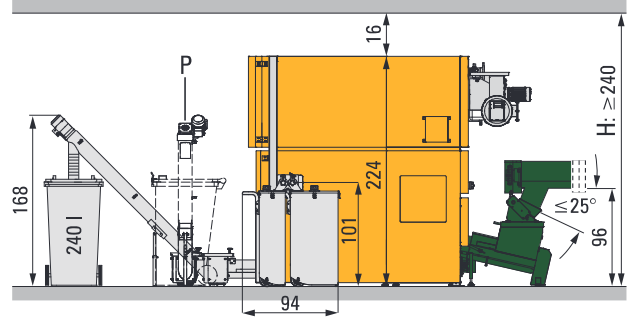

External ash container 240 l on the right and heat exchanger ash removal in a convenient design (A3)

Wall duct for swing range of the conveyor system

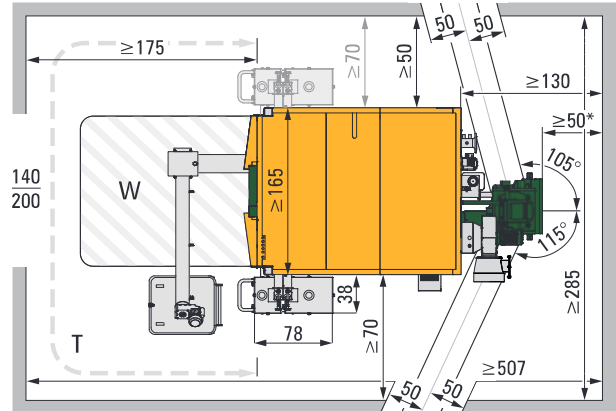

External, small ash container 66 l front (A4)

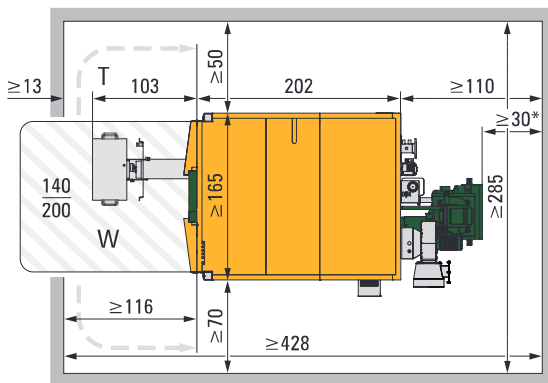

Minimum room dimensions

	Minimum room dimensions of the built-in ash container variants (cm)				
	Ash-container position				
	Left	Front	Right	Front (66 l)	Any
Version:	A1	A2	A3	A4	
Room width (B)	360	285	285	285	370
Room length (L)	487	537	507	428	560
Room height (H)	240	240	240	240	240

Connecting dimensions

KWB Powerfire 240/300kW

Drawing

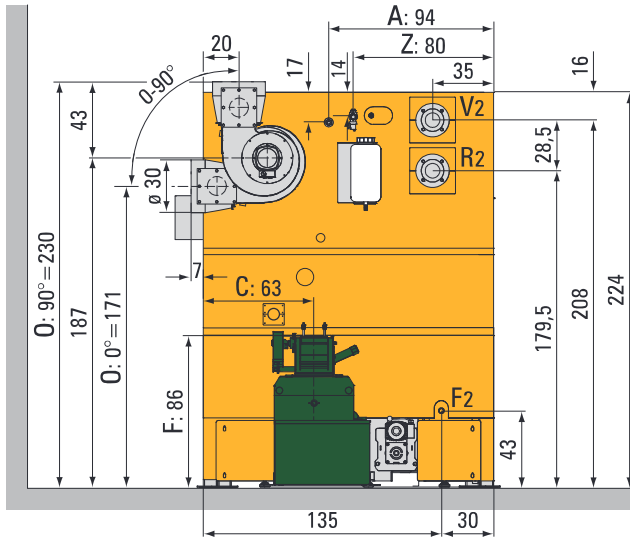

Side view

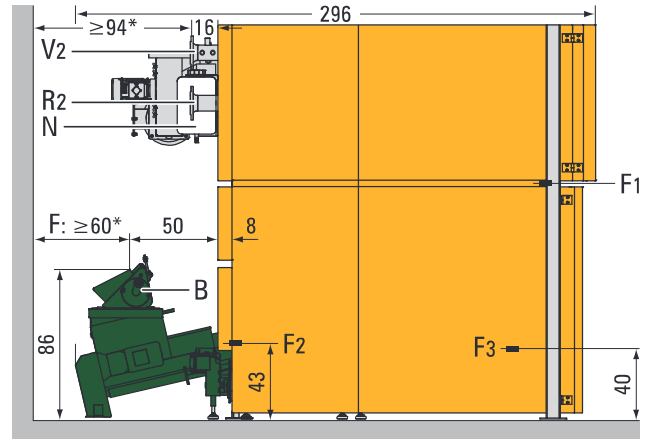

Plan view

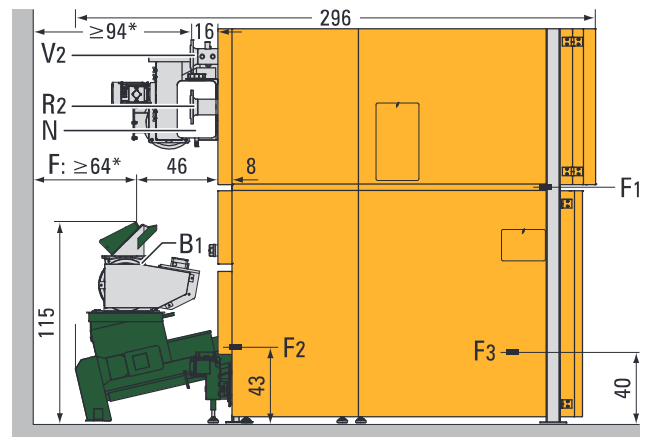
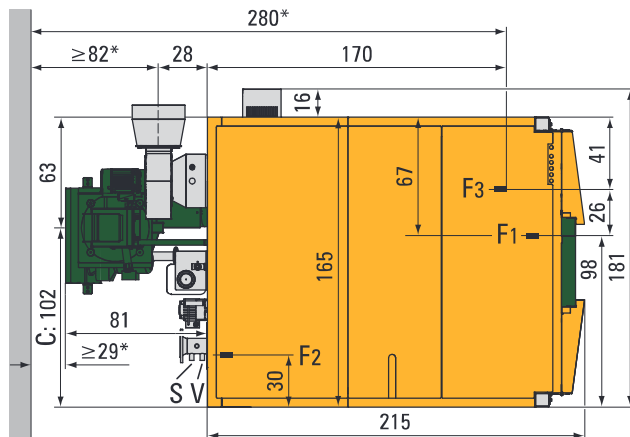

Legend

A	Flow for thermal safety valve ¾" (internal thread)
B	Fire shutter
BI	Cellular wheel sluice (alternative to the fire shutter)
C	Conveyor system axle
E	E-Filter
F	Conveyor system connection
F1	Boiler emptying point ¾" (internal thread) - area of heat exchanger (front over the burner chamber door)
F2	Boiler emptying point ¾" (internal thread) - flame pipe area
F3	Boiler filling and emptying ¾" (internal thread) - area of burner housing (in front under the burner chamber door)

N	Emergency fire-extinguishing equipment
O	Smoke pipe
R1	Return flow DN 50, PN 6
R2	Return flow DN 50, PN 6
S	Sensor for safety boiler temperature limit
V	Sensor for forward flow temperature
V2	Forward flow DN 80, PN 6
Z	Inflow for thermal safety valve ¾" (internal thread)

* Conveyor system connection: The distance is valid if the conveyor system is installed horizontally and vertically with 0°. If the conveyor system is at an angle (-105° to +115° or -105° to +90° with E-Filter) and/or inclined (≥25°), the distance to the brickwork behind the installation must be increased by ≥20 cm.

All illustrations are shown without the external ash removal system. All distances stated are minimum dimensions and apply only to the installation variants shown! With regards to space requirements also pay attention to smoke pipe routing and chimney position – the space requirement for reducers and elbows can influence the minimum distances! It must be possible to detach the entire casing at any time.

Classicfire
Combifire

Easyfire 1
Easyfire 1 Plus

Easyfire

Pelletfire^{Plus}

Multifire

Powerfire

Control
C3 & C4

Conveyor and
storage
systems

Storage and
hydraulic
systems

Installation dimensions with E-Filter

KWB Powerfire 240/300kW with E-Filter

- Classicfire Combifire
- Easyfire 1 Easyfire 1 Plus
- Easyfire
- Pelletfire Plus
- Multifire
- Powerfire
- Control C3 & C4
- Conveyor and storage systems
- Storage and hydraulic systems

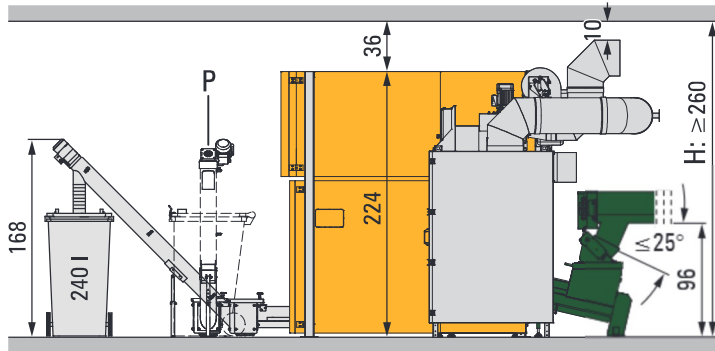

Standard model with E-Filter on the right

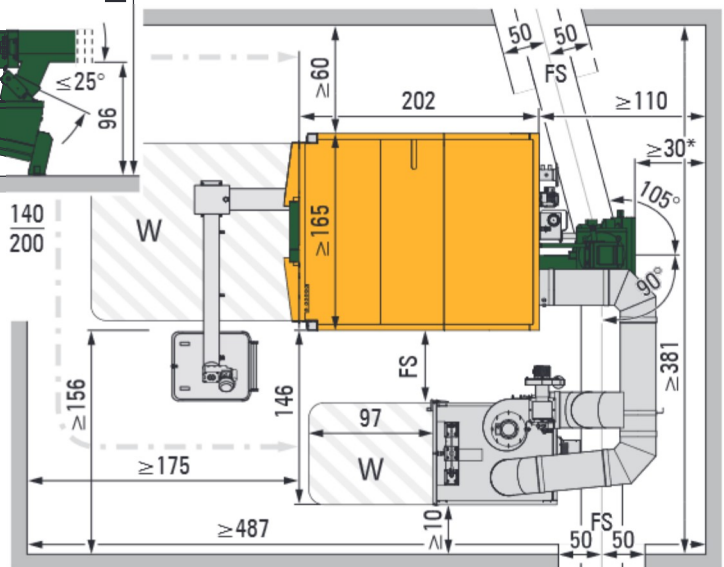

Standard model with E-Filter on the left

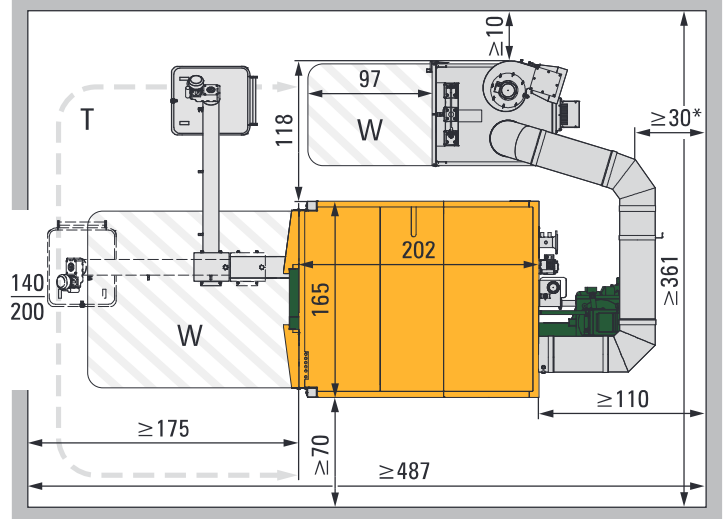

Legend

FS	It is recommended to always place the conveyor system on the E-Filter side to keep open the access to the maintenance areas. In this case, the recommended distance between E-Filter and boiler is ≥ 40 cm instead of ≥ 60 cm.
H	If a bypass attachment is planned, the min. room height increases by ≥ 40 cm.

P	Alternative position
D	Door area: valid for all models. The door must be in the drawn-in area – deviations require consultation with KWB! If the door is not directly in front of the system, the space requirement in front of the system increases to at least ≥ 225 cm.
W	Maintenance area

* If the conveyor system is installed diagonally, the planning must include an additional clearance of ≥ 20 cm to the rear wall! Take the gear unit position and motor position into account.
 REI90 according to ÖNORM EN 13501, EI2 30-C according to ÖNORM EN 13501, E30 according to ÖNORM EN 13501
 All distances stated are minimum dimensions and apply only to the installation variants shown! With regards to space requirements also pay attention to smoke pipe routing and chimney position – the space requirement for reducers and elbows can influence the minimum distances! It must be possible to detach the entire casing at any time. The minimal room dimensions for the ash containers as displayed in the illustration. Individual planning is possible after consultation with KWB.

Installation dimensions with E-Filter

KWB Powerfire 240/300kW with E-Filter

Standard model with E-Filter on the right

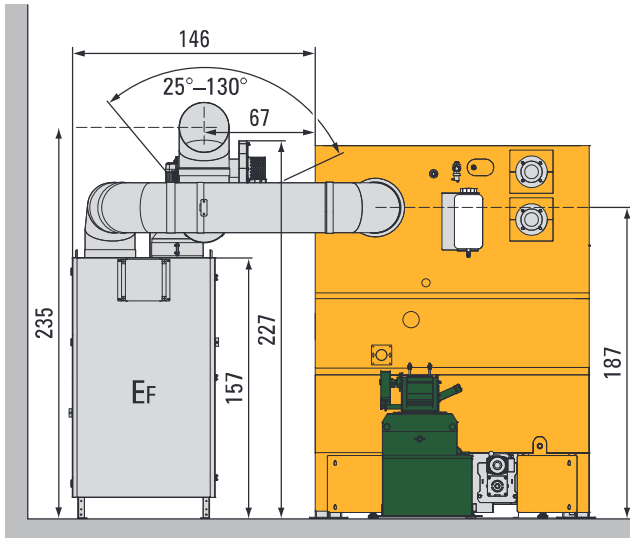

Standard model with E-Filter on the left

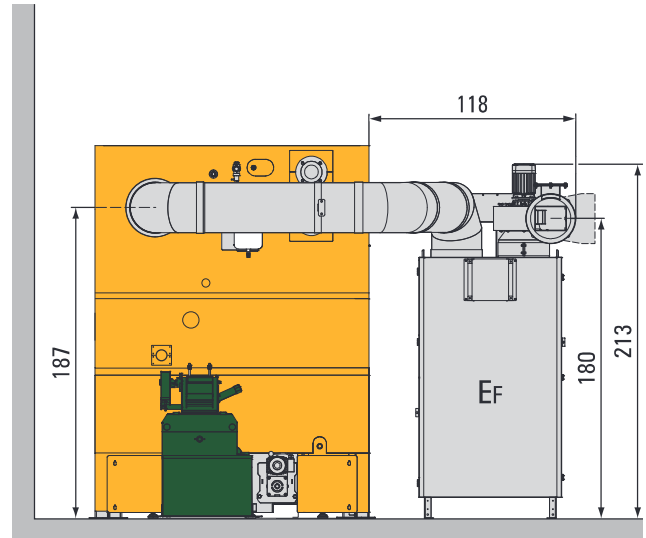

Standard model with E-Filter on the right

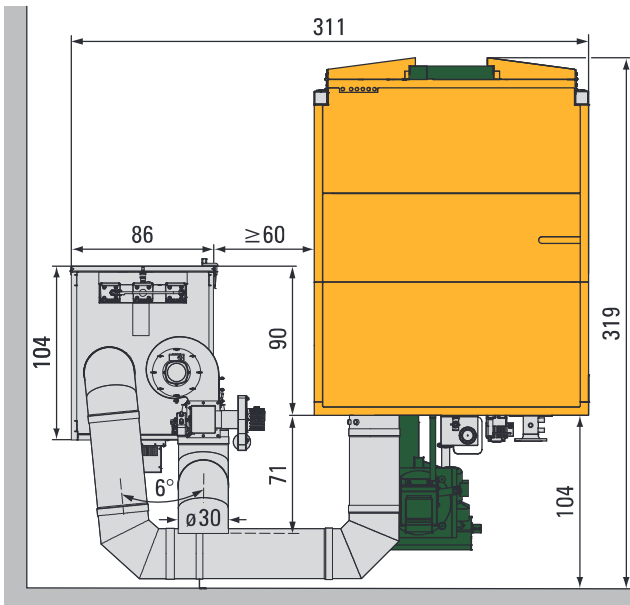

Standard model with E-Filter on the left

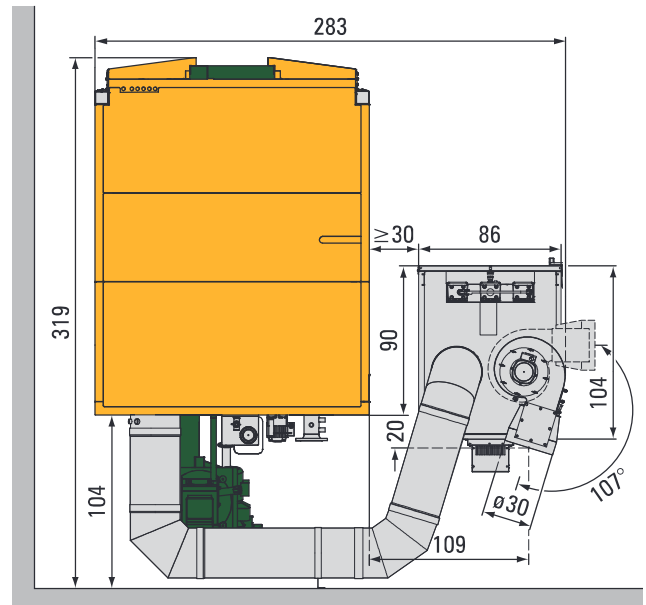

Classicfire
Combifire

Easyfire 1
Easyfire 1 Plus

Easyfire

Pelletfire^{Plus}

Multifire

Powerfire

Control
C3 & C4

Conveyor and
storage
systems

Storage and
hydraulic
systems

Installation dimensions with cyclone

KWB Powerfire 240/300kW with cyclone dust separator

Standard model with cyclone dust separator on the right

Drawing

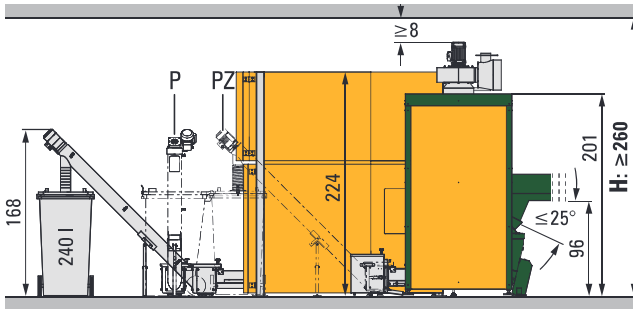

Layout

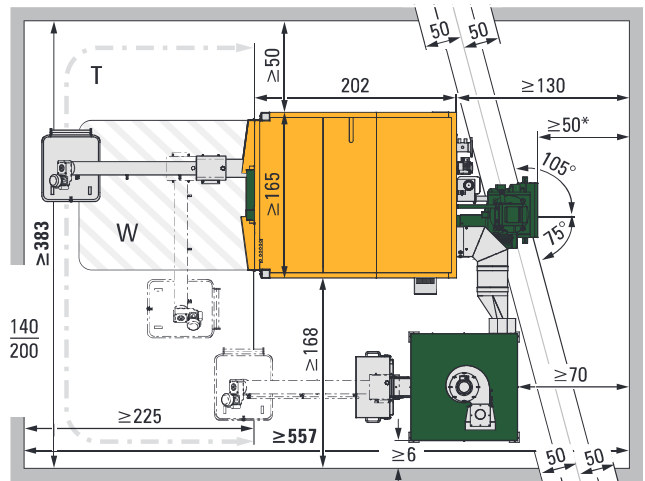

Standard model with cyclone dust separator on the left

Layout

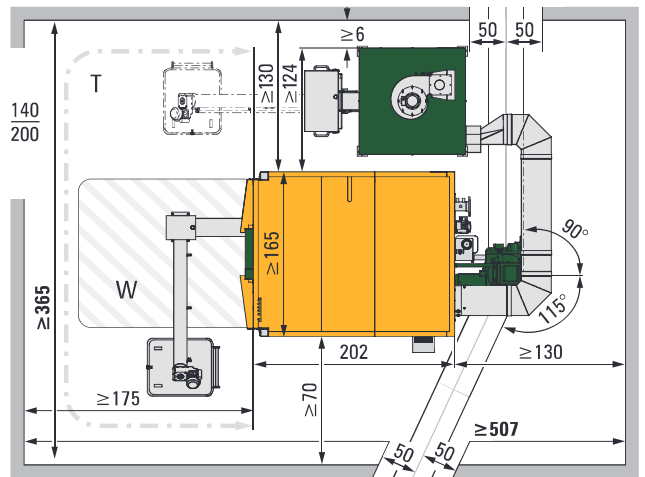

Legend

H	Room height: For room heights below 280 cm, the customer must provide suitable lifting tools (electrical forklift, wheel front loader, etc.).
P	Alternative position
PZ	Position 240 l ash container for cyclone dust separator

T	Door area: valid for all models. The door must be in the drawn-in area – deviations require consultation with KWB! If the door is not directly in front of the system, the space requirement in front of the system increases to at least ≥225 cm.
W	Maintenance area

* If the conveyor system is installed diagonally (swing range: -105° to +115°), the planning must include an additional clearance of ≥20 cm to the rear wall!
 Take the gear unit position and motor position into account.
 REI90 according to ÖNORM EN 13501, EI2 30-C according to ÖNORM EN 13501, E30 according to ÖNORM EN 13501
 All distances stated are minimum dimensions and apply only to the installation variants shown! With regards to space requirements also pay attention to smoke pipe routing and chimney position – the space requirement for reducers and elbows can influence the minimum distances! It must be possible to detach the entire casing at any time. The minimal room dimensions for the ash containers as displayed in the illustration. Individual planning is possible after consultation with KWB.

Connecting dimensions with cyclone

KWB Powerfire 240/300kW with cyclone dust separator

Standard model with cyclone dust separator on the right

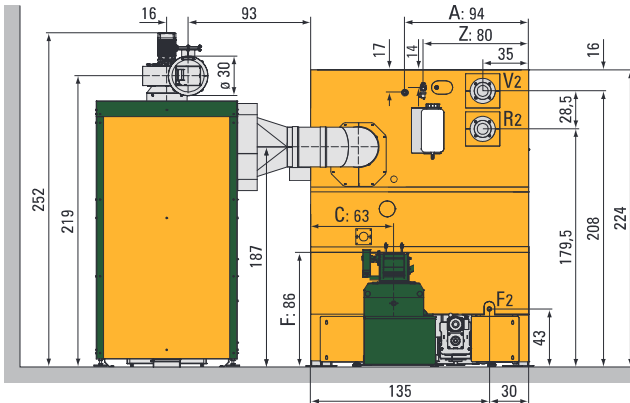

Standard model with cyclone on the left

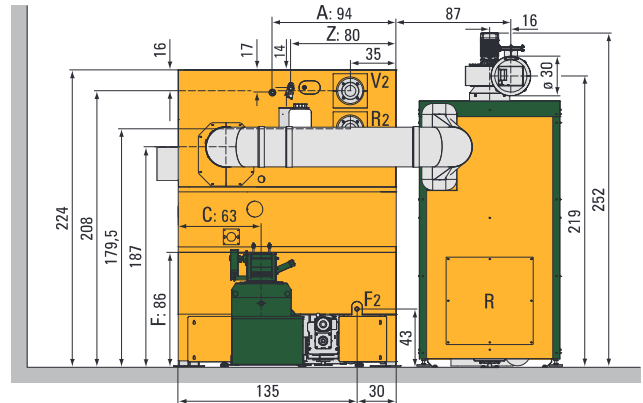

Standard model with cyclone dust separator on the right

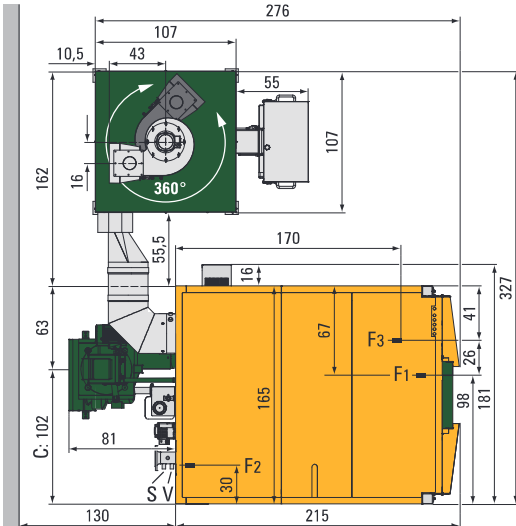

Standard model with cyclone on the left

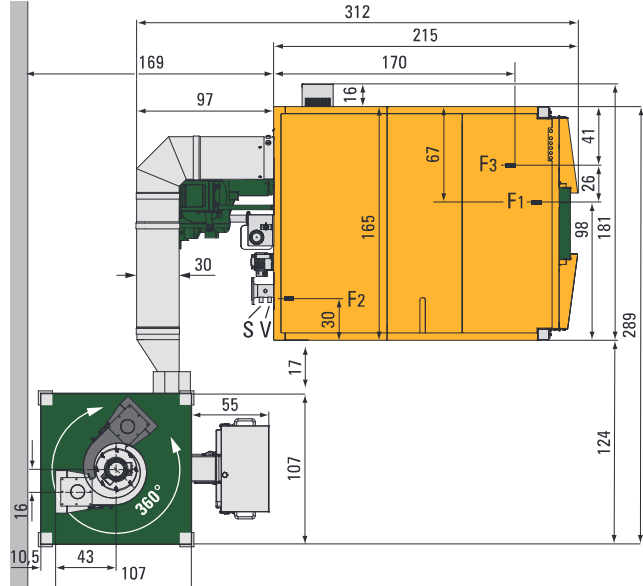

Legend

A	Flow for thermal safety valve 3/4" (internal thread)
C	Conveyor system axle
F	Conveyor system connection
F1	Boiler emptying point 3/4" (internal thread) – area of heat exchanger (in front over combustion chamber door)
F2	Boiler emptying point 3/4" (internal thread) – flame pipe area
F3	Boiler filling and emptying point 3/4" (internal thread) – area of burner housing (in front under the burner chamber door)

R	Maintenance cover
R2	Return flow DN 80, PN 6
S	Sensor for safety boiler temperature limit
V	Sensor for forward flow temperature
V2	Forward flow DN 80, PN 6
Z	Inflow for thermal safety valve 3/4" (internal thread)

All illustrations are shown without the external ash removal system. All distances stated are minimum dimensions and apply only to the installation variants shown! With regard to space requirements, please also pay attention to the smoke pipe routing and chimney position – the space requirements for reducers and elbows may influence the minimum distances! It must be possible to detach the entire casing at any time.

Classicfire
Combifire

Easyfire 1
Easyfire 1 Plus

Easyfire

Pelletfire Plus

Multifire

Powerfire

Control
C3 & C4

Conveyor and
storage
systems

Storage and
hydraulic
systems

Water-side resistance

KWB Powerfire 130-300 kW

Classicfire
Combifire

Easyfire 1
Easyfire 1 Plus

Easyfire

Pelletfire Plus

Multifire

Powerfire

Control
C3 & C4

Conveyor and
storage
systems

Storage and
hydraulic
systems

TDS 130

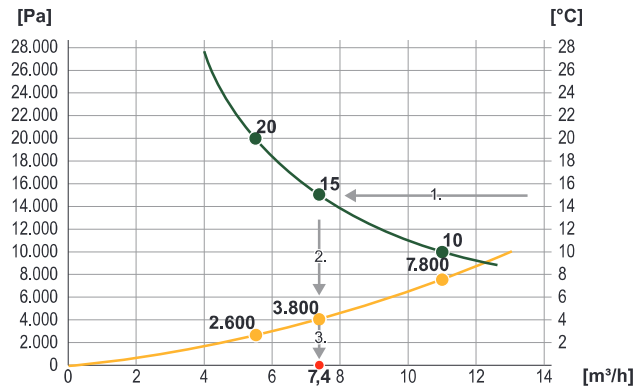

TDS 150

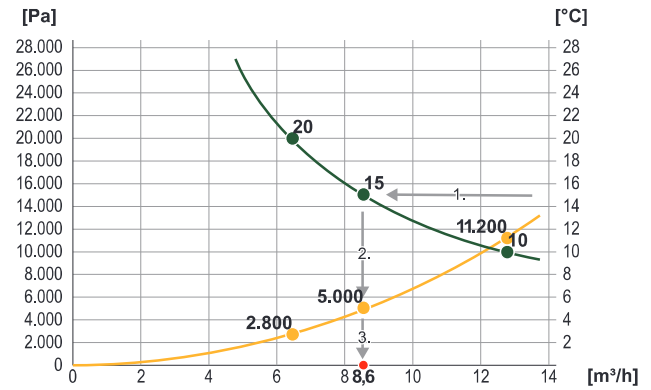

TDS 200*

* Only available in the UK

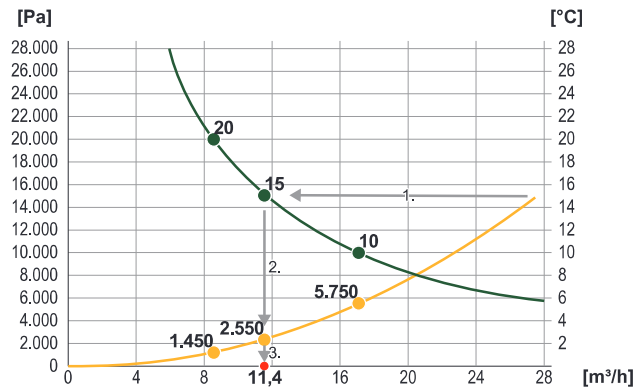

TDS 240

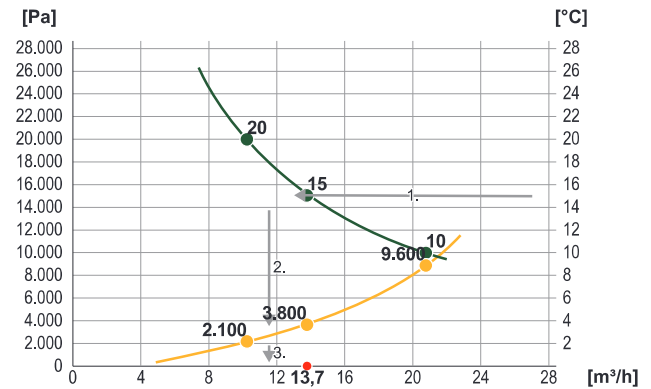

TDS 300

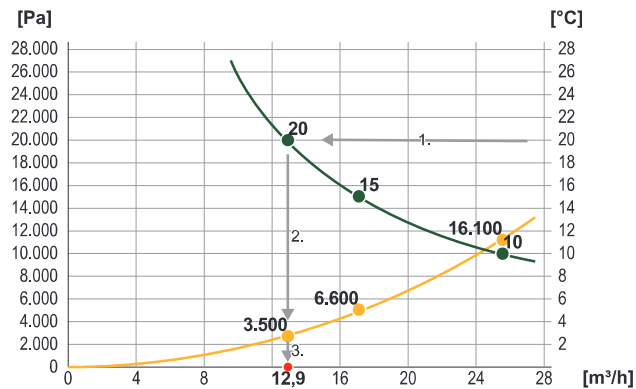

Legend

1/	Read from right to left up to the intersection of the spread
2.	Read downward up to the intersection of the resistance
3.	Read downward up to the volume flow
●	HW-side resistance
—	HW-side resistance
●	HW-side spread
—	HW-side spread

Recommended parameters for boiler circuit pumps, control valves and return flow mixers

Boiler pumps - parameters		Control valve or return-flow mixer
Boiler performance [kW]	min. Ø forward, return flow	Kvs [m³/h]
130	DN50	44
150	DN50	44
200*	DN80	63
240	DN80	63
300	DN80	63

* Only available in the UK

Classicfire Combifire
Easyfire 1 Easyfire 1 Plus
Easyfire
Pelletfire ^{Plus}
Multifire
Powerfire
Control C3 & C4
Conveyor and storage systems
Storage and hydraulic systems

Technical specifications

KWB Powerfire 130-300 kW

Classicfire
Combifire

Easyfire 1
Easyfire 1 Plus

Easyfire

Pelletfire Plus

Multifire

Powerfire

Control
C3 & C4

Conveyor and
storage
systems

Storage and
hydraulic
systems

TDS	Unit	TDS 130		TDS 150		TDS 200 ⁷		TDS 240		TDS 300	
		Pellet	Wood chips	Pellet	Wood chips	Pellet	Wood chips	Pellet	Wood chips	Pellet	Wood chips
Rated power	kW	130	130	150	150	199	199	245	245	300	300
Partial load	kW	39,0	39,0	45,0	45,0	59,7	59,7	73,5	73,5	73,5	73,5
Boiler efficiency at rated power	%	91,9	91,0	93,2	92,5	93,7	93,9	93,8	92,7	94,4	92,9
Boiler efficiency at partial load	%	91,6	90,6	92,1	92,4	91,6	91,8	93,4	91,8	93,4	91,8
Fuel thermal output at rated power	kW	141	143	161	162	212	212	261	264	318	323
Fuel thermal output at partial load	kW	43	43	49	49	65	65	79	80	79	80
Boiler class according to EN 303-5:2012	-	5	3	5	5	4	4	5	5	5	5
Water side											
Water content	l	295	295	295	295	610	610	610	610	610	610
Water connection diameter flow/return (flange)	-	DN 50 PN 6	DN 50 PN 6	DN 50 PN 6	DN 50 PN 6	DN 80 PN 6	DN 80 PN 6	DN 80 PN 6	DN 80 PN 6	DN 80 PN 6	DN 80 PN 6
Water connection for thermal safety valve	inch mm	3/4 19,05	3/4 19,05	3/4 19,05	3/4 19,05	3/4 19,05	3/4 19,05	3/4 19,05	3/4 19,05	3/4 19,05	3/4 19,05
Thermal safety valve: temperature ¹	°C	10	10	10	10	10	10	10	10	10	10
Thermal safety valve: pressure ¹	bar	2	2	2	2	2	2	2	2	2	2
Boiler filling and emptying at the burner (internal thread)	inch mm	3/4 19,05	3/4 19,05	3/4 19,05	3/4 19,05	3/4 19,05	3/4 19,05	3/4 19,05	3/4 19,05	3/4 19,05	3/4 19,05
Boiler emptying at the flame pipe (internal thread)	inch mm	-	-	-	-	3/4 19,05	3/4 19,05	3/4 19,05	3/4 19,05	3/4 19,05	3/4 19,05
Boiler emptying at the heat exchanger (internal thread)	inch mm	-	-	-	-	3/4 19,05	3/4 19,05	3/4 19,05	3/4 19,05	3/4 19,05	3/4 19,05
Water-side resistance at 20 K ²	Pa mbar	26 2600	26 2600	28 2800	28 2800	15 1450	15 1450	22 2200	22 2200	32 3200	32 3200
Water-side resistance at 10 K ²	Pa mbar	78 7800	78 7800	112 11200	112 11200	58 5750	58 5750	88 8800	88 8800	129 12900	129 12900
Boiler inlet temperature ≤w30	°C	55-70	55-70	55-70	55-70	55-70	55-70	55-70	55-70	55-70	55-70
Boiler inlet temperature >w30	°C	-	65-70	-	65-70	-	65-70	-	65-70	-	65-70
Working temperature/operating temperature	°C	90	90	90	90	90	90	90	90	90	90
Maximum permitted temperature	°C	95	95	95	95	95	95	95	95	95	95
Maximum operating pressure	bar	3,5	3,5	3,5	3,5	3,5	3,5	3,5	3,5	3,5	3,5
Flue-gas side (data for chimney design)											
Combustion chamber temperature	°C	900-1200	900-1000	900-1200	900-1000	900-1200	900-1000	900-1200	900-1000	900-1200	900-1000
Combustion chamber pressure	mbar	-0,2.. -0,3	-0,2.. -0,3	-0,2.. -0,3	-0,2.. -0,3	-0,2.. -0,3	-0,2.. -0,3	-0,2.. -0,3	-0,2.. -0,3	-0,2.. -0,3	-0,2.. -0,3
Delivery pressure at rated power / partial load	mbar	0,10 0,06	0,10 0,06	0,10 0,06	0,10 0,06	0,10 0,06	0,10 0,06	0,10 0,06	0,10 0,06	0,10 0,06	0,10 0,06
Induced draught required	-	✓	✓	✓	✓	✓	✓	✓	✓	✓	✓
Exhaust-gas temperature at rated power / partial load	°C	160 80	160 80	160 80	160 80	160 80	160 80	160 80	160 80	160 80	160 80
Exhaust-gas connection height (boiler side)	mm	1.615	1.615	1.615	1.615	-	-	-	-	-	-
Exhaust-gas connection height: variant up	mm	-	-	-	-	1.970	1.970	1.970	1.970	1.970	1.970
Exhaust-gas connection height: variant right (pipe centre, 0-90° pivoting) ⁵	mm	-	-	-	-	1.380	1.380	1.380	1.380	1.380	1.380
Exhaust-gas connection diameter	mm	250	250	250	250	300	300	300	300	300	300
Incline of the exhaust-gas pipe	°	≥ 3	≥ 3	≥ 3	≥ 3	≥ 3	≥ 3	≥ 3	≥ 3	≥ 3	≥ 3
Recommended chimney diameter	mm	300	300	300	300	350	350	350	350	350	350
Chimney design: moisture-resistant	-	✓	✓	✓	✓	✓	✓	✓	✓	✓	✓
		M10	M30 M45	M10	M30 M45	M10	M30 M45	M10	M30 M45	M10	M30 M45
Exhaust-gas mass flow at rated power ³	kg/s	0,084	0,098 0,107	0,108	0,137 0,157	0,134	0,140 0,164	0,160	0,176 0,192	0,193	0,215 0,234
Exhaust-gas mass flow at partial load ³	kg/s	0,025	0,029 0,032	0,031	0,038 0,044	0,041	0,046 0,050	0,048	0,055 0,060	0,048	0,055 0,060
Exhaust-gas volume at rated power ³	Nm ³ /h	234	277 308	300	388 455	376	398 475	446	499 555	538	607 674
Exhaust-gas volume at partial load ³	Nm ³ /h	70	83 93	87	130 180	115	131 145	133	155 173	133	155 173
Fuel according to ISO 17225-2 / 17225-4											
Maximum water content	-	M10	M45	M10	M45	M10	M45	M10	M45	M10	M45
Maximum fuel size	-	D89	P31S	D89	P31S	D89	P31S	D89	P31S	D89	P31S
Water content for type testing (fresh weight) ⁴	kg/kg WB	0,084	0,222	0,04	0,223	0,082	0,223	0,056	0,322	0,059	0,317

TDS	Unit	TDS 130	TDS 150	TDS 200 ⁷	TDS 240	TDS 300
Ash						
Ash-container volume – fly-ash	l	23	23	23	23	20+44
Ash-container volume – grate-ash	l	66	66	66	66	66
Ash container, grate ash, full	kg	75	75	75	75	75
Ash-container volume, comfort version (optional)	l	-	-	-	-	66+125
Ash-removal system	-	✓	✓	✓	✓	✓
Ash-container volume (optional)	l	240	240	240	240	240
Weight of ash container, full	kg	~265	~265	~265	~265	~265
Electrical system						
Connection: 5-pin	-	400 V _{AC} 50 Hz 16 A	400 V _{AC} 50 Hz 16 A	400 V _{AC} 50 Hz 16 A	400 V _{AC} 50 Hz 16 A	400 V _{AC} 50 Hz 16 A
Unit switch and main switch: present	-	✓	✓	✓	✓	✓
Connected power boiler	W	3,010	3,010	3,010	3,600	3,600
Connected power total incl. fuel extractor	W	4,510	4,510	4,510	5,100	5,100
Auxiliary power consumption in trial operation at rated power ⁵	kW _{el} /MW _{th}	2,00	3,10	1,43	2,23	1,53
Auxiliary power consumption in trial operation at partial load ⁵	kW _{el} /MW _{th}	3,40	5,00	3,01	5,13	2,19
Auxiliary power consumption at rated power ⁵	W	260	390	209	313	320
Auxiliary power consumption at partial load ⁵	W	130	190	132	220	130
Standby power	W	29	29	29	29	29
Weights						
Heat exchanger incl. cleaning grille	kg	725	725	725	725	900
Burner housing incl. chamotte	kg	796	796	796	796	866
Flame pipe incl. chamotte	kg	-	-	-	-	965
Stoker trough	kg	113	113	113	113	137
Total weight (empty)	kg	1.634	1.634	1.634	1.634	2.868
Assembly case	kg	174	174	174	174	288
Weight of transport packaging (in each case)	kg	25	25	25	25	25
Noise emissions⁶						
Normal operating noise at rated power	dB(A)	60	60	60	60	63
Operating peaks at rated power	dB(A)	68	68	68	68	65
Test report						
Test report no.	-	07-UW/Wels-EX-269/3	14-UW/Wels-EX-321/4	07-UW/Wels-EX-269/2	14-UW/Wels-EX-321/5	14-UW/Wels-EX-321/6

27.1.2015

- 1 ... In acc. with EN 303-5; higher temperatur respectively lower minimum admission pressure available on request
 - 2 ... The water-side restistance is specified and determined in each case on the boiler interface (flange RF/FF)
 - 3 ... with reference to damp flue gas
 - 4 ... Wood chips: Provision of the rated power to M30, above there is a reduction in power dissipation.
 - 5 ... Measured values for the additional power requirement are understood to include KWB stirrer extractors incl. standard trough (NOT with sliding floor).
 - 6 ... The noise measurements were executed in normal operation with wood chips. Leq(A) at 1 m distance (ISO 11202:1995)
 - 7 ... Only available in the UK
 - 8 ... Values only for standard-boiler-configuration. NOT for cellular wheel sluice, cyclone or E-Filter (own dimensioned drawings)
- mg/Nm³ ... Milligram per standard cubic meter (Nm³... under 1013 hectopascal at 0 °C)

Information regarding the hydraulics requirements can be found at www.kwb.en.

Classicfire
Combifire
Easyfire 1
Easyfire 1 Plus
Easyfire
Pelletfire Plus
Multifire
Powerfire
Control C3 & C4
Conveyor and storage systems
Storage and hydraulic systems